



Tsunami Aerator Pump Installation Instructions

SAVE THESE INSTRUCTIONS
Form Number 69391 Rev. A

10-03

⚠ DANGER

If Aerator is installed thru-hull, remove boat from water to service this pump. Do not use this pump to remove gasoline or other flammable liquids.

⚠ WARNING

Most of the aerator pump, plumbing and connections are below the water level. Do not attempt to install, adjust, service or remove this product while the boat is in the water. Failure to follow these instructions could result in a large volume of water flooding and sinking your boat. Any leak will allow water to enter the boat.

To prevent personal injury, always disconnect the power source when installing or servicing any electrical product.

Use the fuse amperage rating specified for your model pump.

Refer to Specification and Accessories Charts to be sure you have selected the proper components:

Specifications Chart

| 12-Volts DC | | ABYC Specifications @13.6 VDC (GPH = Gal. Per Hour) | | | ISO Specifications @12.0 VDC (LPH = Liters Per Hour) | | | | |
|-------------|--------|---|----------|---------------------|--|----------------------|--------------------|---------------------|------------------------------|
| Part Num. | Series | Hole Saw Size | Amp Fuse | 0 ft. Head GPH/amps | 3.3 ft Head GPH/amps | 6.7 ft Head GPH/amps | 0kPa Head LPH/amps | 10kPa Head LPH/amps | Max Head (ft.@13.6v/kPa@12v) |
| 4640 | 500 | 1-1/8" | 2.5A | 500/1.8 | 440/1.8 | 265/1.8 | 1705/1.5 | 1420/1.5 | 10' 5"/30 |
| 4650 | 800 | 1-1/8" | 4A | 800/3.0 | 670/3.0 | 525/3.0 | 2900/2.6 | 2350/2.6 | 14'/35 |
| 4660 | 1200 | 1-3/8" | 5A | 1200/3.5 | 900/3.5 | 700/3.5 | 4320/3.4 | 3145/3.4 | 10' 5"/26 |

Accessories Chart

| | | A. | B. | C. | D. | E. | F. | G. | H. |
|---------------------------|--------|-----------------|-----------------------------|-----------------------|----------------------------------|----------------|---------------------|------------|-----------------------------|
| 3/4" O.D. Outlet Models | | | | | | | | | |
| Part Num. | Series | Inlet Hose I.D. | 3/4" Inlet Hose Connector | 3/4" O.D. Thru Hull | 3/4" Threaded Outlet Connector | Remote Bracket | S.S. Inlet Strainer | Spray Head | Replacement Motor Cartridge |
| 4640 | 500 | 3/4" | 3899 | 66547 | 3890, 90° | 4122 | 4232 | 4125 | 4620 |
| 4650 | 800 | 3/4" | 3899 | 66547 | 3890, 90° | 4122 | 4232 | 4125 | 4622 |
| 1-3/8" O.D. Outlet Models | | | | | | | | | |
| Part Num. | Series | Inlet Hose I.D. | 1-1/8" Inlet Hose Connector | 1-1/8" O.D. Thru Hull | 1-3/8" Threaded Outlet Connector | Remote Bracket | S.S. Inlet Strainer | Spray Head | Replacement Motor Cartridge |
| 4660 | 1200 | 1-1/8" | 3902 | 66548 | 3902, 90° | 4121 | 4234 | 4127 | 4624 |

MOUNTING LOCATIONS

- The aerator can be mounted directly through the transom, at least 2" (51mm) below the static water line. (Figure 1)

Figure 1

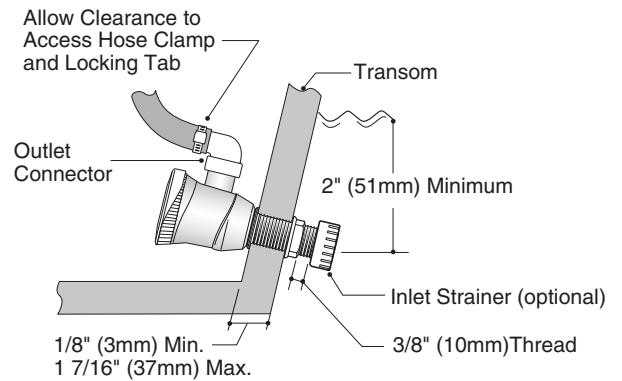

- The aerator can also be remotely installed on a marine-plywood mounting pad. This requires an Attwood Remote Bracket — see Accessories Chart for size. (Figure 2)

Figure 2

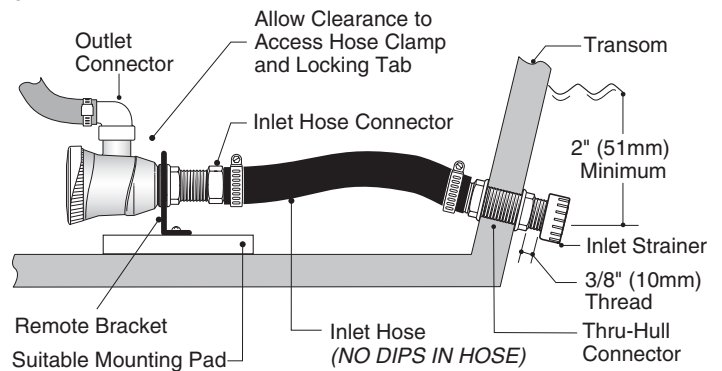

IMPORTANT: To avoid airlock, do not allow dips or sharp bends in outlet or inlet hoses.

DIRECT MOUNTING INSTRUCTIONS

See Accessories Chart for size / part number of Outlet Hose Connector.

- With boat out of the water, select a suitable location at least 2" (51mm) below the water line. Use a hole saw (See Specification Chart for size — compare against aerator inlet) to drill a hole through the transom. (Figure 1)
- Apply polyurethane marine sealant (Boat-Life Lifeseal® or equivalent) to the nut and to threaded side of the aerator flange.
- Install the aerator inlet through the transom and assemble the nut. Tighten the nut handtight. Use wrench to tighten 1/2 additional turn.

⚠ WARNING

DO NOT EXCEED these tightening specifications.

- Install Attwood 90° Outlet Connector to the aerator outlet. Tighten the fitting handtight, then 1/4 to 1/2 additional turn with wrench.
- Use an Inlet Strainer to avoid clogging of the pump.

REMOTE MOUNTING INSTRUCTIONS

See Accessories Chart for sizes / part numbers of Thru-Hull, Bracket, and Inlet Hose.

- With boat out of water, install Thru-Hull Connector through the transom. (Figure 2)

CAUTION: DO NOT drill through the bottom of the boat when installing Remote Bracket.

- Attach Remote Bracket to the mounting pad by drilling two 1/8" (3mm)-diameter pilot holes and fastening with two #8 stainless steel pan head screws. Position aerator on Bracket so pump outlet is pointed straight up.
- Complete outlet fitting and hose connection as described above.
- Connect a length of reinforced, smooth bore Inlet Hose from the Thru-Hull to the aerator Inlet Hose Connector. Use a hose clamp at each end of the hose.

LIVEWELL CONNECTION INSTRUCTIONS

See Accessories Chart for sizes / part numbers of Outlet Hose and Spray Head.

1. Connect outlet hose from the aerator outlet fitting to the Spray Head. Use a hose clamp at each end of the hose. (Figure 3)

IMPORTANT: Route the hose as straight as possible with an upward angle. Avoid dips or sharp bends that can create airlock and hinder water flow.

2. An aerator pump can be connected to the bottom of a livewell to recirculate water within the tank.

Figure 3

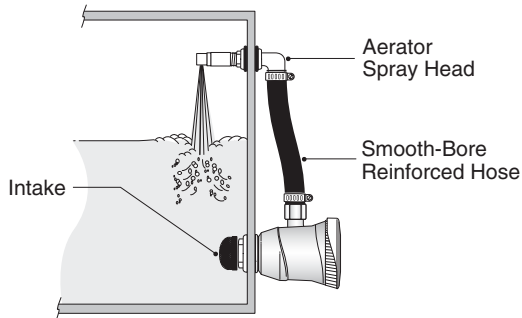

WIRING INSTRUCTIONS

The power source to the pump must be a 12-volt DC battery ONLY. Protect circuit with fuse (see chart) and make all wire connections above the highest possible water level, using marine grade wire connectors only. Waterproof all connections with suitable materials. (Figure 4)

CAUTION: Failure to make waterproof connections and fuse pump properly will void the product warranty.

Figure 4

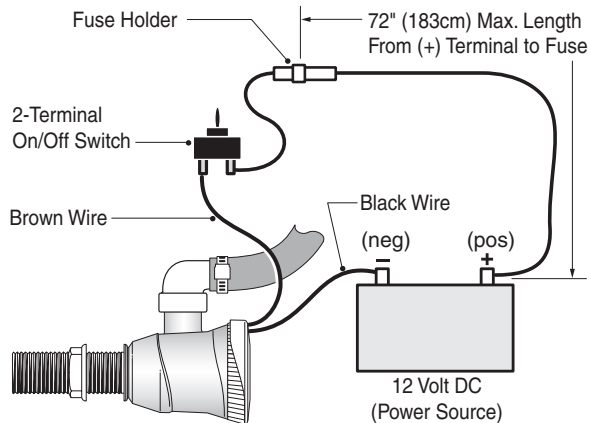

CARE AND MAINTENANCE

⚠ WARNING

If Aerator is installed thru-hull, BOAT MUST BE OUT OF THE WATER to remove or replace aerator motor cartridge.

1. With boat out of water, occasionally remove Motor Cartridge and check pump to be certain debris is not restricting or jamming the impeller. Hold outlet with one hand and depress red locking tab with other. Twist Motor Cartridge counter-clockwise and remove from housing. (Figure 5)

Figure 5

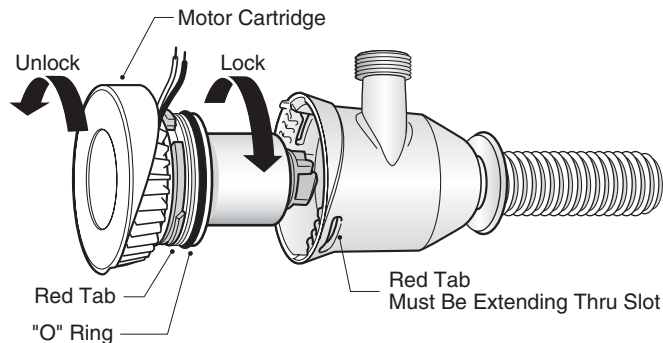

2. Be sure "O" ring is not damaged, nicked or worn. Lubricate the "O" ring area with vegetable oil to ease re-assembly.
3. To install new Motor Cartridge (H), see Accessories Chart for part number. Motor must match housing color: 500 Series = RED, 800 = BLUE, 1200 = GRAY.
4. Align motor cartridge red tab with slot on aerator housing. Push in and turn clockwise.

⚠ WARNING

To avoid leaking or sinking, the RED TAB MUST BE LOCKED AND EXTENDING through aerator housing slot.

ATTWOOD AERATOR PUMPS LIMITED WARRANTY

This Attwood Aerator Pump carries a three (3) year warranty. See product catalog or www.attwoodmarine.com for details.